



**Product Guide**

**[www.bestbuysteel.com](http://www.bestbuysteel.com)**

**Tel:** 1300 76 88 48

**Toll Free:** 1800-BUY-STEEL  
1800 28 97 83

**Mobile:** 0413 619 767

**Fax:** (08) 9200 5600

**Postal Address:** PO Box 7223  
Shenton Park, WA 6008

**Email:** [sales@bestbuysteel.com](mailto:sales@bestbuysteel.com)

**Location:**

**Wattleup**  
365 Wattleup Rd,  
Hammond Park, WA 6164

**For conditions of sale, please refer to the end of this document, just before the Alphabetical Index.**

## Table of Contents

Corrugated Roof & Wall Sheeting.....	5
Steelclad Roof & Wall Sheeting .....	6
(compatible with Trimdek®) .....	6
Eavesline Guttering.....	7
Colonial Guttering.....	8
QuickFix Guttering.....	9
Square Guttering – Small & Large.....	10
Valley Guttering.....	11
Round Downpipe.....	12
Rectangular Downpipe.....	13
Rolled Top Ridge Capping.....	14
Flat Top Ridge Capping.....	15
Fascia.....	16
Ceiling Batten.....	17
Roof Batten.....	17
Standard Barge Capping.....	18
Standard Apron Flashing.....	18
100 x 100 mm Corner Mould.....	19
150 x 150 mm Corner Mould.....	19
Overflashing – Wedge (Cover Flashing).....	20
Hookover Flashing.....	20
Secret Gutter.....	21
Custom Flashings.....	21
Fasteners.....	22
Building Blanket Insulation.....	23
Flume Vents.....	23
Top Hat.....	24
Junction Stud.....	25
Stud Framing.....	26
Top Plate & Trim Angle.....	27
C Purlins.....	28
Z Purlins.....	29
Channel.....	30
Patio Tube – Galvanised or in Colorbond® Colours.....	31
Square Hollow Section – Painted or Black.....	32
Rectangular Hollow Section – Painted or Black.....	35
Square Hollow Section – Galvanised.....	38
Rectangular Hollow Section – Galvanised.....	40
Conditions of Sale.....	42

***We can also supply some other materials. Please contact us with your requirements and we will advise if we can help.***

**This page intentionally blank**

# Corrugated Roof & Wall Sheeting

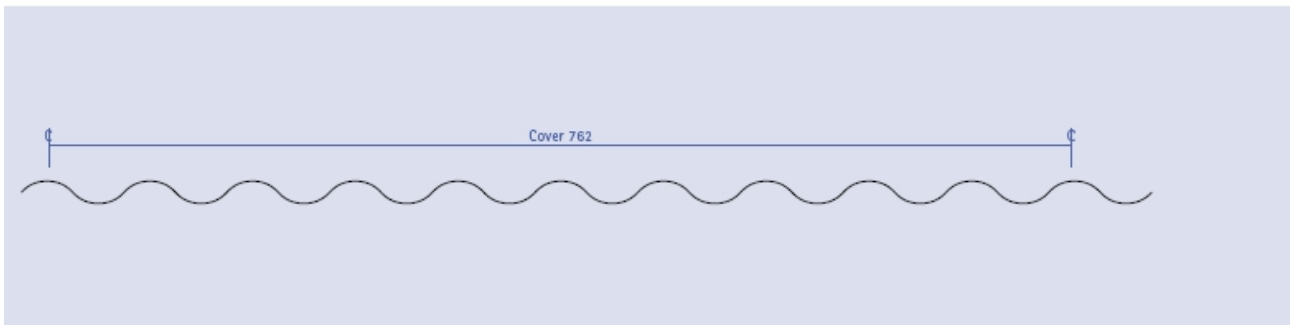

## Details

**0.42mm BMT / 0.47mm TCT or  
0.48mm BMT / 0.53mm TCT**

## Finishes

**Zincalume®  
Colorbond®**

## Available Lengths

## Must be ordered cut-to-length

Recommended specifications	0.42 Bmt	0.48 Bmt
Cover width	762mm	762mm
Nominal sheet depth	17mm	17mm
Minimum recommended slope	5° (1 in 12)	5° (1 in 12)
Roof span - internal	1.20m	1.60m
Roof span - end	900mm	1.20m
Wall span - internal	1.80m	2.40m
Wall span - end	1.35m	2.00m

Overall width: 855mm

# Steelclad Roof & Wall Sheeting

(compatible with Trimdek®)

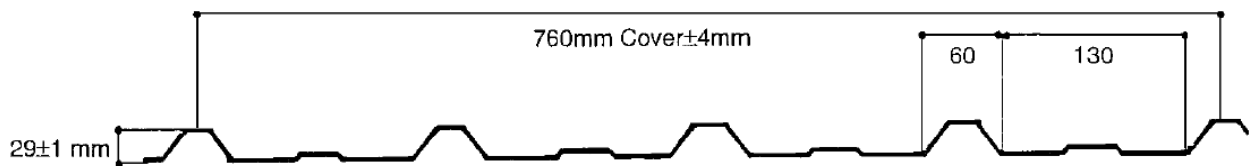
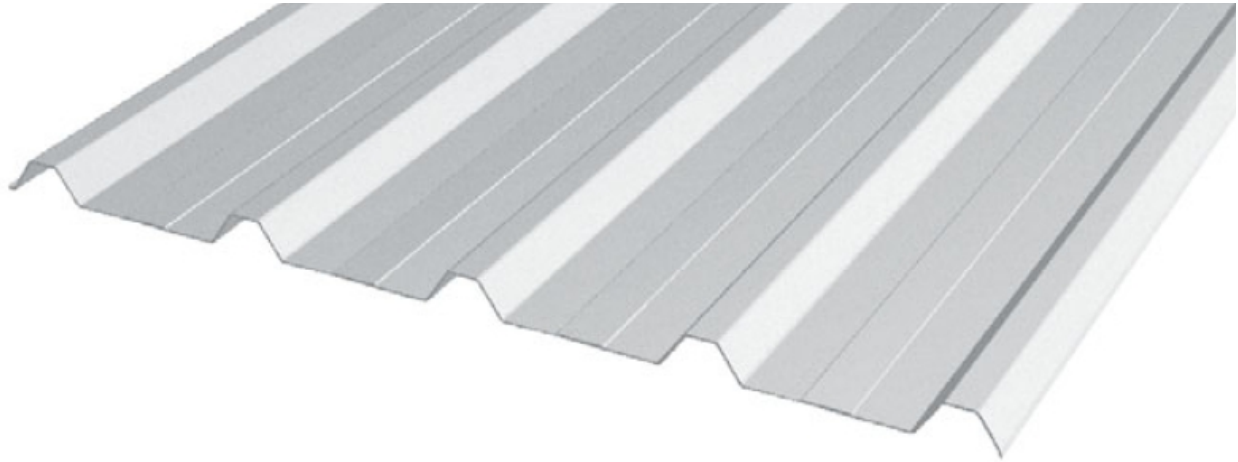

## Details

**0.42mm BMT / 0.47mm TCT or  
0.48mm BMT / 0.53mm TCT**

## Finishes

**Zincalume®  
Colorbond®**

## Available Lengths

**Must be ordered cut-to-length**

Recommended specifications	0.42 Bmt	0.48 Bmt
Cover width	762mm	762mm
Nominal sheet depth	30mm	30mm
Minimum recommended slope	2° (1 in 30)	2° (1 in 30)
Roof span - internal	1.70m	2.30m
Roof span - end	1.00m	1.70m
Wall span - internal	2.20m	2.80m
Wall span - end	1.80m	2.50m

Overall width:

827mm

# Eavesline Guttering

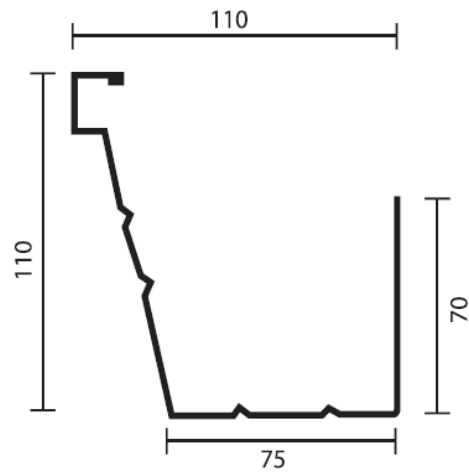

## Details

**0.40mm TCT**

## Finishes

**Zincalume®**

**Colorbond®**

## Accessories

**Stop Ends (L/H and R/H)**

**Clips**

## Stock Lengths

**7.0m (Zincalume® & some colours)**

**Mitres (Internal and External)**

**Can be ordered cut-to-length**

## **Colonial Guttering**

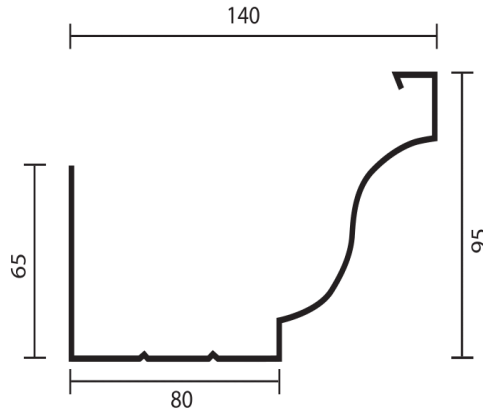

### **Details**

**0.40mm TCT**

### **Finishes**

**Zincalume®**

**Colorbond®**

### **Accessories**

**Stop Ends (L/H and R/H)**

**Clips**

### **Stock Lengths**

**7.0m (Zincalume® & some colours)**

**Mitres (Internal and External)**

**Can be ordered cut-to-length**



# QuickFix Guttering

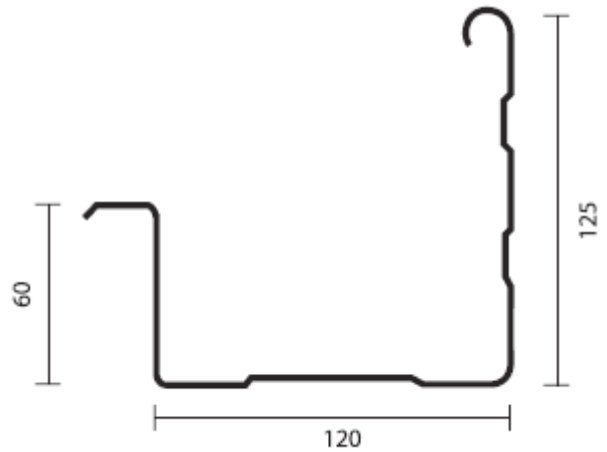

## Details

**0.40mm TCT**

## Finishes

**Zincalume®**

**Colorbond®**

## Accessories

**Stop Ends (L/H and R/H)**

## Stock Lengths

**7.0m (Zincalume® & some colours)**

**Can be ordered cut-to-length**

# Square Guttering – Small & Large

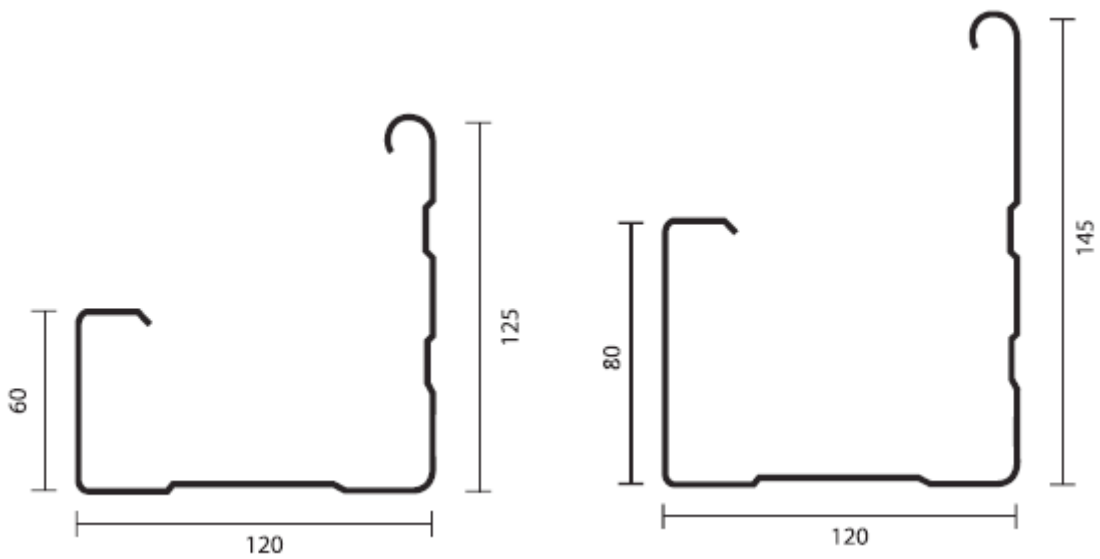

## Details

**0.40mm TCT**

## Finishes

**Zincalume®**

**Colorbond®**

## Accessories

**Stop Ends (L/H and R/H)**

**Clips**

**Mitres (Internal and External)**

## Stock Lengths

**7.0m (Zincalume® and some colours)**

**Can be ordered cut-to-length**

# Valley Guttering

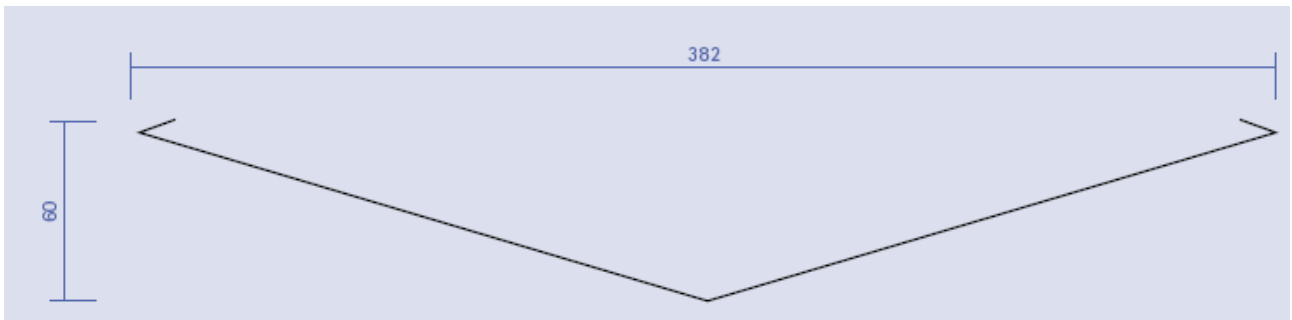

## Details

**430mm Girth**

**0.40mm TCT**

## Finishes

**Zincalume<sup>®</sup>**

**Colorbond<sup>®</sup>**

## Stock Lengths

**1.8 and 2.4m (Zincalume<sup>®</sup> only)**

**Can be ordered cut-to-length**

# Round Downpipe

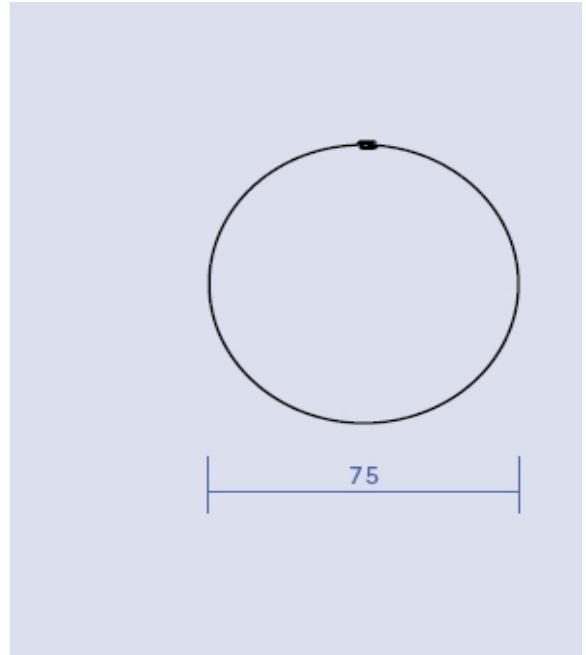

## Details

**75mm**

**0.40mm TCT**

## Finishes

**Zincalume®**

**Colorbond®**

## Accessories



**Clip**



**Pop**

## Available Lengths

**1.8 and 2.4m lengths**

# Rectangular Downpipe

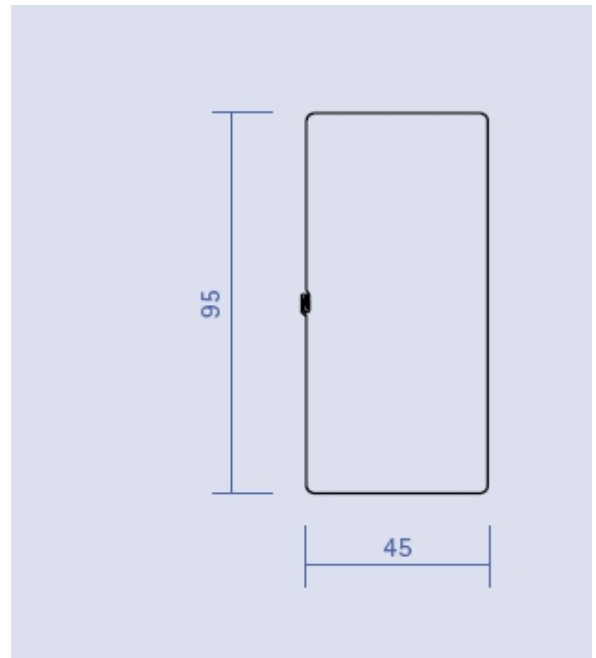

## Details

**95 x 45 mm**  
**0.40mm TCT**

## Finishes

**Zincalume®**  
**Colorbond®**

## Accessories

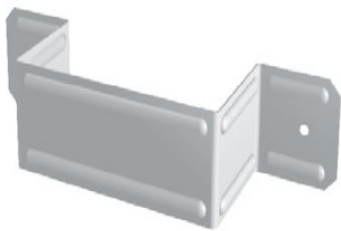

**Clip**



**Pop**

## Available Lengths

**1.8 and 2.4m lengths**

# Rolled Top Ridge Capping

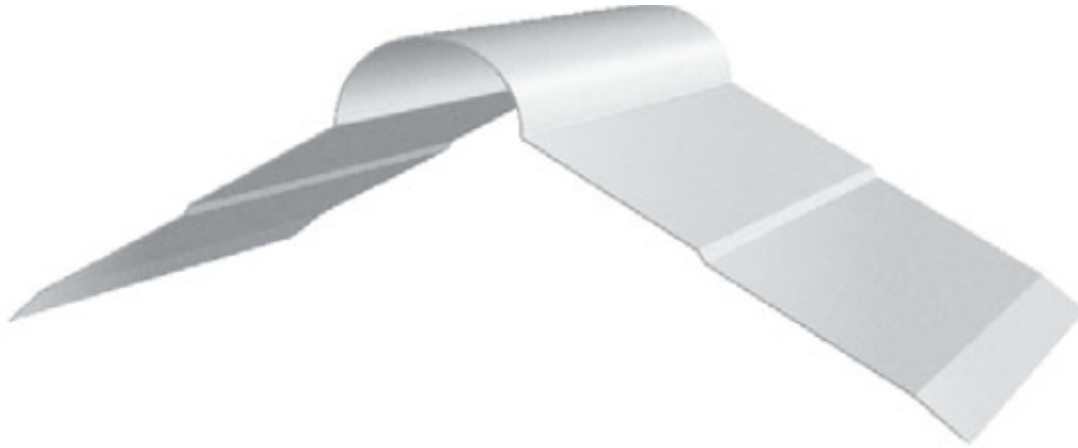

## Details

**390mm Girth**

**0.40mm TCT**

## Finishes

**Zincalume®**

**Colorbond®**

## Available Lengths

**Must be ordered cut-to-length**

# Flat Top Ridge Capping

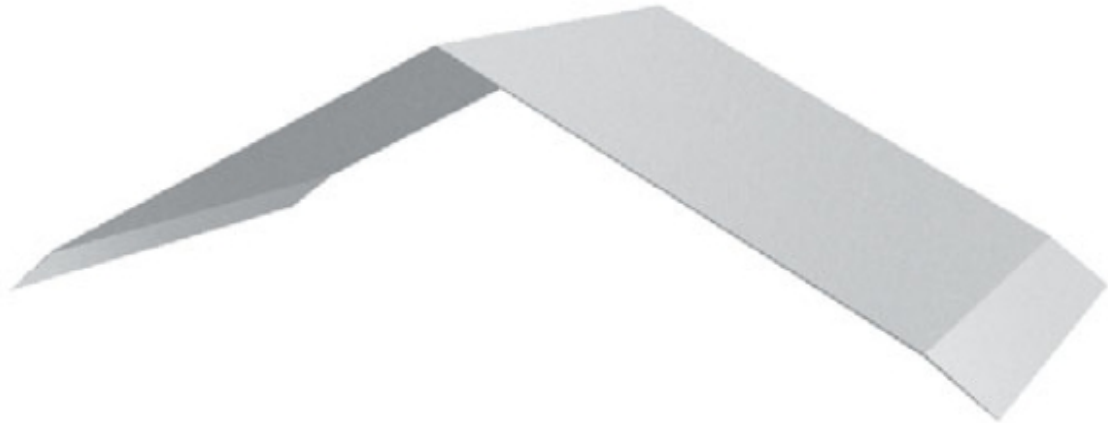

## Details

**390mm Girth**

**0.40mm TCT**

## Finishes

**Zincalume<sup>®</sup>**

**Colorbond<sup>®</sup>**

## Available Lengths

**Must be ordered cut-to-length**

# Fascia

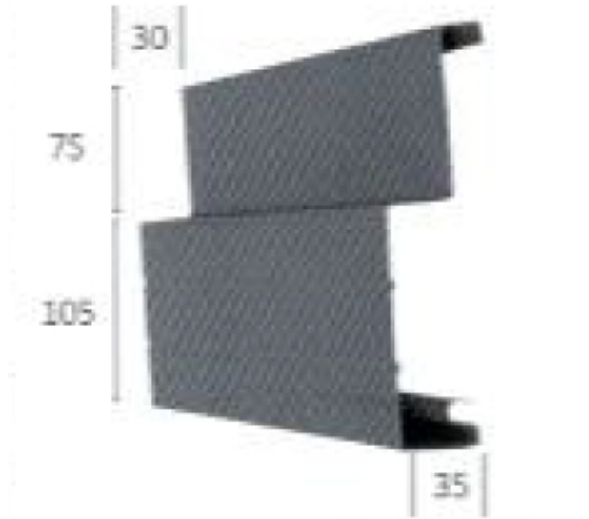

## Details

**0.65mm TCT**

**G300**

## Finishes

**Zincalume®**

**Colorbond®**

## Accessories

**Standard Fixing Clip**

**Side Fixing Clip**

**Corners (Internal/External)**

**Corners (135° External / 45°  
Internal)**

**Joiner Sleeve**

**Stop Ends (L/H or R/H)**

## Available Lengths

**Must be ordered cut-to-length from  
1.0 – 8.0m lengths in 0.5m  
increments**



## Ceiling Batten

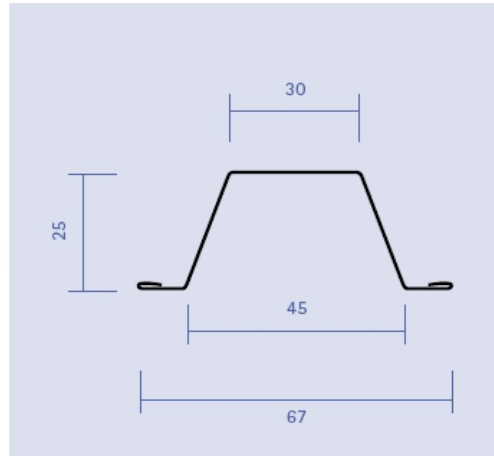
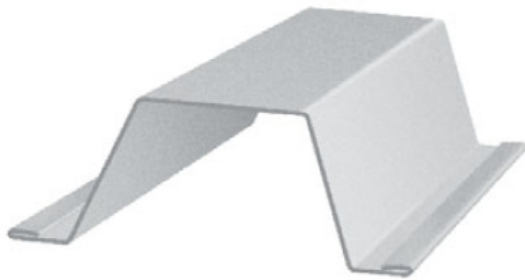

**Details**  
**0.42mm BMT**

**Finishes**  
**Galvanised**

**Stock Lengths**  
**6.1m**

## Roof Batten

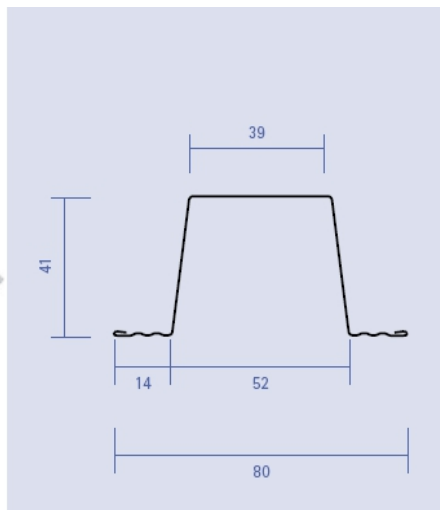

**Details**  
**0.55mm BMT**

**Finishes**  
**Galvanised**

**Stock Lengths**  
**6.1m**

## Standard Barge Capping

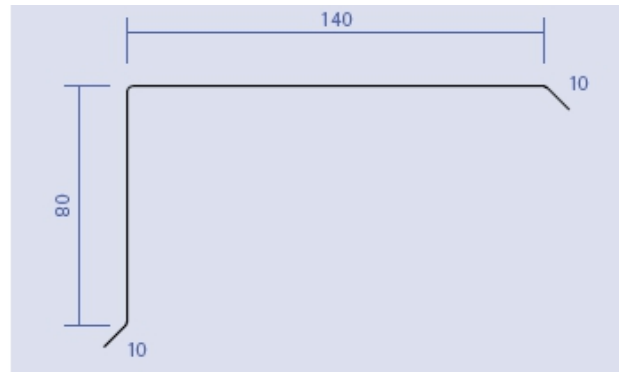
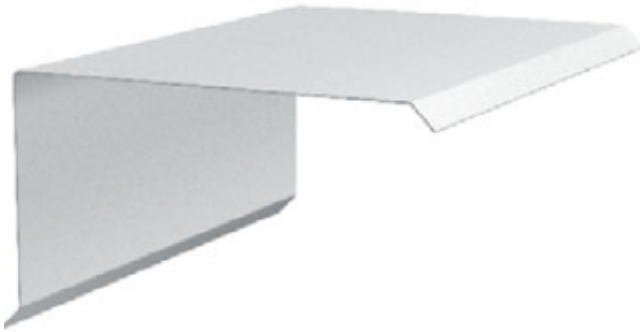

### Details

**240mm Girth**

**0.40mm TCT**

### Finishes

**Zincalume®**

**Colorbond®**

### Available Lengths

**Must be ordered cut-to-length**

## Standard Apron Flashing

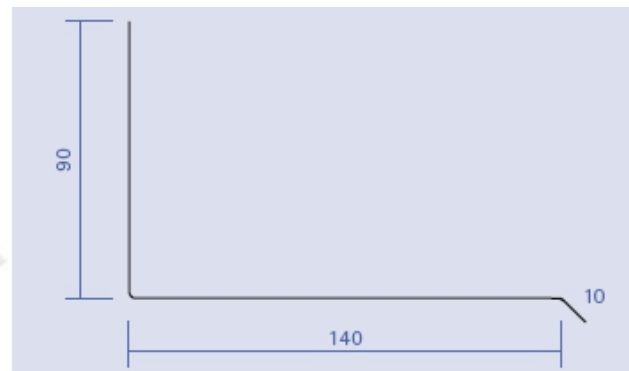

### Details

**240mm Girth**

**0.40mm TCT**

### Finishes

**Zincalume®**

**Colorbond®**

### Available Lengths

**Must be ordered cut-to-length**

## 100 x 100 mm Corner Mould



### Details

**100 x 100 mm**

**0.40mm TCT**

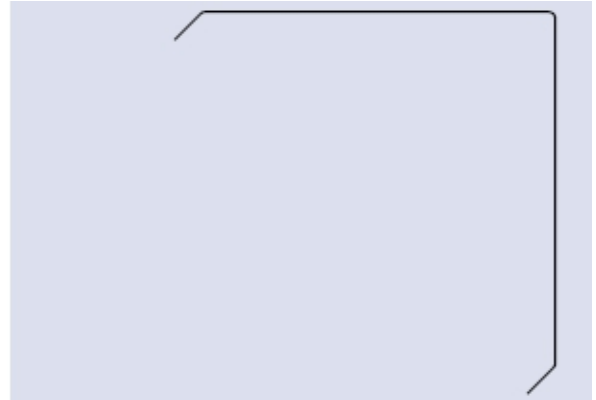

### Finishes

**Zincalume®**

**Colorbond®**

### Available Lengths

**Must be ordered cut-to-length**

## 150 x 150 mm Corner Mould



### Details

**150 x 150 mm**

**0.40mm TCT**

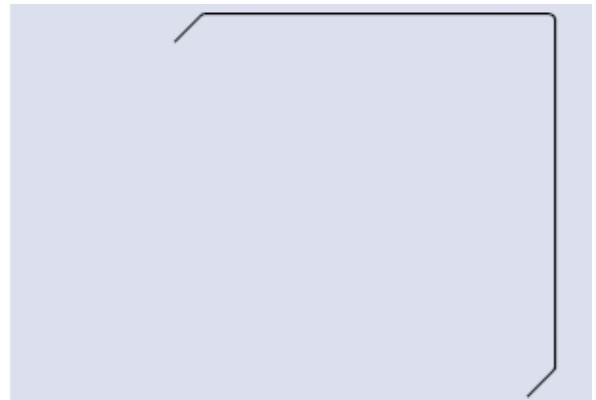

### Finishes

**Zincalume®**

**Colorbond®**

### Available Lengths

**Must be ordered cut-to-length**

## Overflashing – Wedge (Cover Flashing)



### Details

**100mm Girth**

**0.40mm TCT**

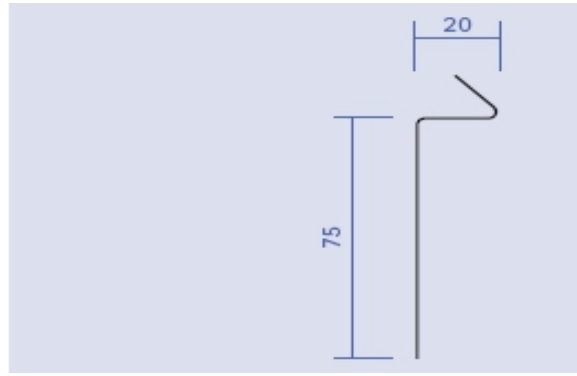

### Finishes

**Zincalume®**

**Colorbond®**

### Available Lengths

**Must be ordered cut-to-length**

## Hookover Flashing



### Details

**300mm Girth (Type A)**

**0.40mm TCT**

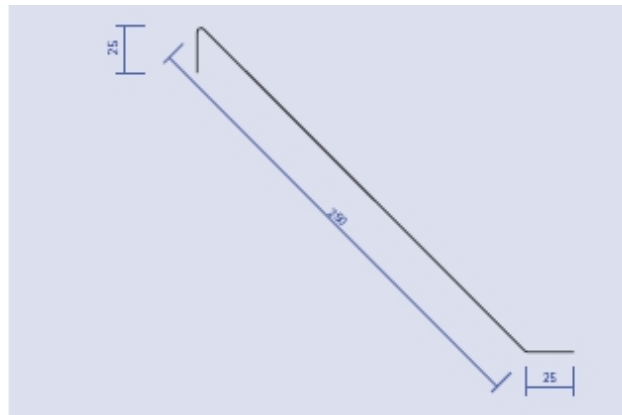

### Finishes

**Zincalume®**

**Colorbond®**

### Available Lengths

**Must be ordered cut-to-length**

# Secret Gutter

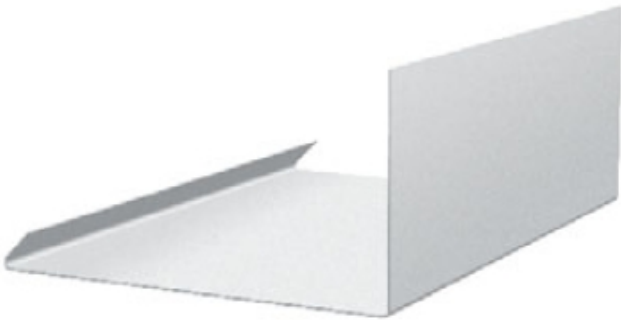

### Details

**225mm Girth**  
**0.40mm TCT**

### Finishes

**Zincalume®**  
**Colorbond®**

### Available Lengths

**Must be ordered cut-to-length**

# Custom Flashings

Custom flashings are available in with 100 – 1200mm girths.

### Details

**0.40mm TCT or**  
**0.60mm TCT**

### Finishes

**Zincalume®**  
**Colorbond®**

### Available Lengths

**Must be ordered cut-to-length**

**Maximum length 8.0m**

# Fasteners



## Sizes Available

**12 x 50mm Type 17 – suit crest fixing of corrugated sheeting to timber**

**12 x 65mm Type 17 – suit crest fixing of Trimdek® profile sheeting to timber**

**12 x 25mm Type 17 – suit pan fixing to timber**

**12 x 35mm Tek – suit suit crest fixing of corrugated sheeting to metal**

**12 x 45mm Tek – suit suit crest fixing of Trimdek® profile sheeting to metal**

**12 x 20mm Tek – suit pan fixing to metal**

**10 x 16mm Tek – suit pan fixing to metal**

**M6 x 50mm Roof Zips – universal – can crest fix to timber and metal**

**Rivets AS4-3**

## Finishes

**Climaseal 3® - AS3566 Class 3**

**Coloured Heads Available to suit Colorbond® colours.**

## Available Quantities

**Boxes of 1000 and in some cases boxes of 500 or bags of 100**

# Building Blanket Insulation

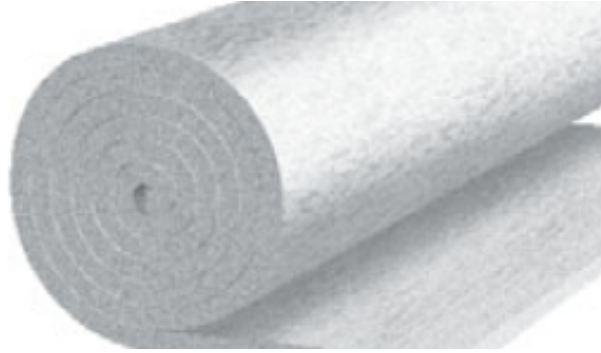

## Details

**Lightweight**

## Thicknesses

**50mm**

**75mm**

## Available Lengths

**50mm: 1.2m x 15m roll (18m<sup>2</sup>)**

**75mm: 1.2m x 10m roll (12m<sup>2</sup>)**

**Supplied in full rolls**

**Sarking foil and galvanised roof safe wire mesh also available.**

# Flume Vents



## Details

**150mm Diameter x 600mm**

**With fitted pitch plate**

## Finishes

**Zincalume<sup>®</sup>**

**Colorbond<sup>®</sup>**

# Top Hat

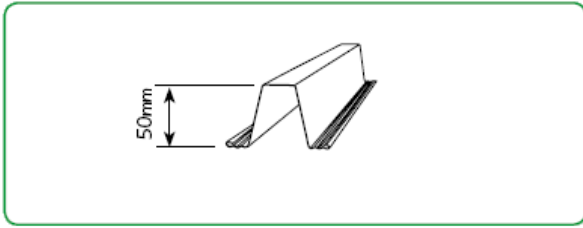

Product	Qty/Pack	APPROX KGS/LIN. MTR	THICKNESS mm	PRICE PER METRE
<b>50mm TOP HAT</b>	100	1.12	0.75	
G 550-Z275	X	1.38	0.95	
	7.5M			

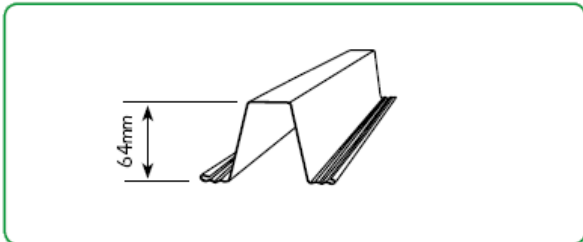

Product	Qty/Pack	APPROX KGS/LIN. MTR	THICKNESS mm	PRICE PER METRE
<b>64mm TOP HAT</b>	100	1.29	0.75	
G 550-Z275	X	1.62	0.95	
	7.5M	1.99	1.15	

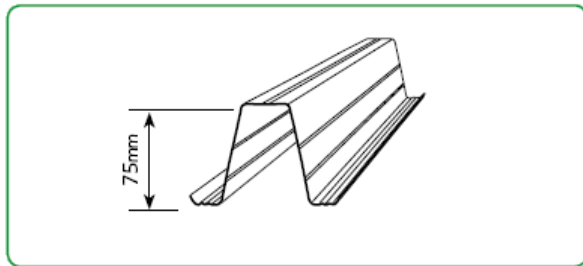

Product	Qty/Pack	APPROX KGS/LIN. MTR	THICKNESS mm	PRICE PER METRE
<b>75mm TOP HAT</b>	100	1.44	0.75	
G 550-Z275	X	1.81	0.95	
	7.5M	2.16	1.15	

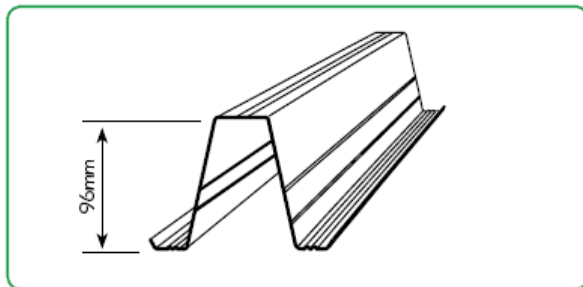

Product	Qty/Pack	APPROX KGS/LIN. MTR	THICKNESS mm	PRICE PER METRE
<b>96mm TOP HAT</b>	100	1.77	0.75	
G 550-Z275	X	2.22	0.95	
	7.5M	2.65	1.15	

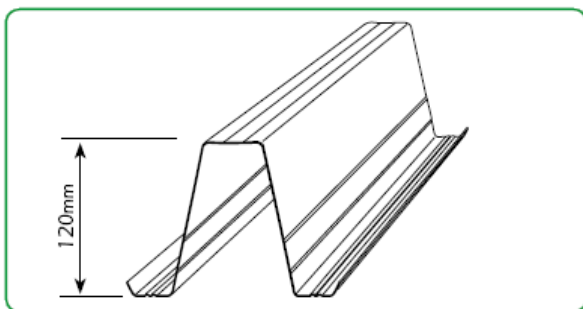

Product	Qty/Pack	APPROX KGS/LIN. MTR	THICKNESS mm	PRICE PER METRE
<b>120mm TOP HAT</b>	100	2.23	0.75	
G 550-Z275	X	2.79	0.95	
	7.5M	3.33	1.15	



# Junction Stud

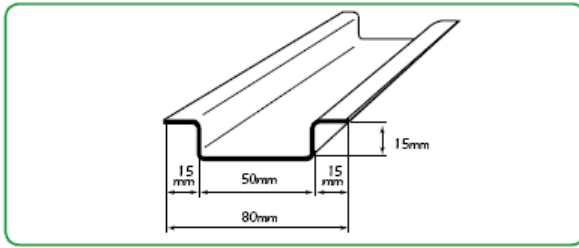

Product	Qty/Pack	APPROX KGS/LIN. MTR	THICKNESS mm	PRICE PER METRE
50 x 15 x 1.15	200 X 3.6M 200 X 6.0M	0.90	1.15	

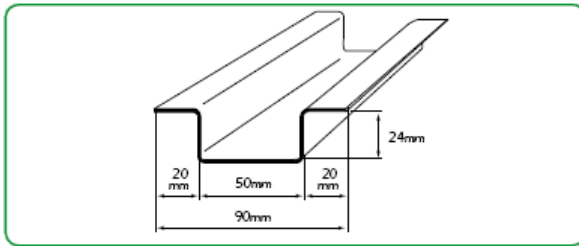

Product	Qty/Pack	APPROX KGS/LIN. MTR	THICKNESS mm	PRICE PER METRE
50 x 24 x 1.15	100 X 3.6M 100 X 6.0M	1.17	1.15	

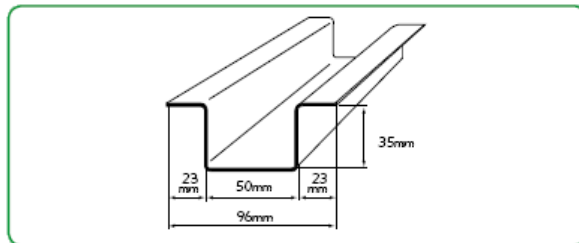

Product	Qty/Pack	APPROX KGS/LIN. MTR	THICKNESS mm	PRICE PER METRE
50 x 35 x 1.15	100 X 6.0M 100 X 7.2M	1.40	1.15	

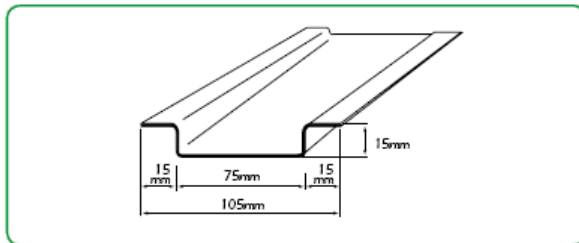

Product	Qty/Pack	APPROX KGS/LIN. MTR	THICKNESS mm	PRICE PER METRE
75 x 15 x 1.15	100 X 6.0M	1.17	1.15	

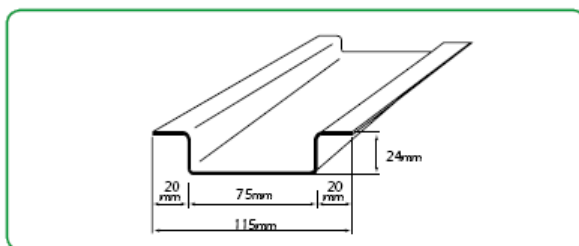

Product	Qty/Pack	APPROX KGS/LIN. MTR	THICKNESS mm	PRICE PER METRE
75 x 24 x 1.15	100 X 6.0M	1.40	1.15	

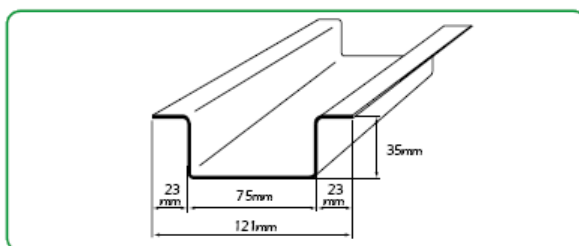

Product	Qty/Pack	APPROX KGS/LIN. MTR	THICKNESS mm	PRICE PER METRE
75 x 35 x 1.15	100 X 6.0M 100 X 7.2M	1.62	1.15	

# Stud Framing

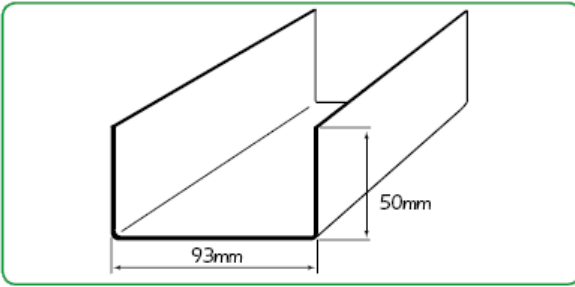

Product	Qty/Pack	APPROX KGS/LIN. MTR	THICKNESS mm	PRICE PER METRE
PLATE 93 x 50 x 1.15	50	1.74	1.15	
STUD 90 x 51 x 1.15				
NOGGIN 87 x 52 x 1.15				

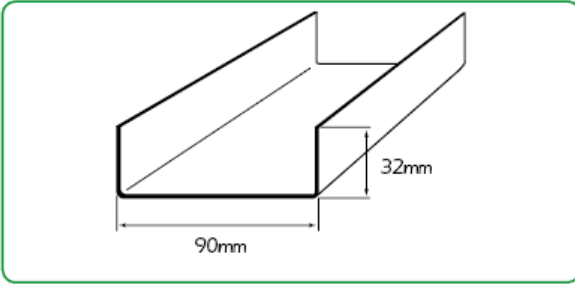

Product	Qty/Pack	APPROX KGS/LIN. MTR	THICKNESS mm	PRICE PER METRE
PLATE 93 x 30 x 1.15	100	1.37	1.15	
STUD 90 x 31 x 1.15				
NOGGIN 87 x 32 x 1.15				

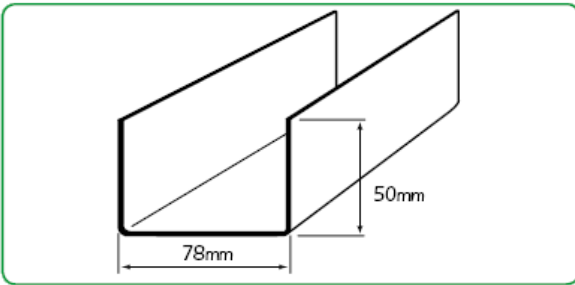

Product	Qty/Pack	APPROX KGS/LIN. MTR	THICKNESS mm	PRICE PER METRE
PLATE 78 x 50 x 1.15	50	1.60	1.15	
STUD 75 x 51 x 1.15				
NOGGIN 72 x 52 x 1.15				

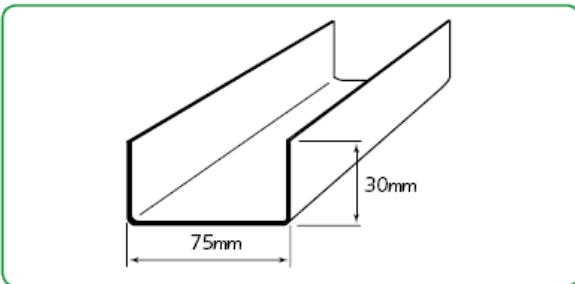

Product	Qty/Pack	APPROX KGS/LIN. MTR	THICKNESS mm	PRICE PER METRE
PLATE 78 x 28 x 1.15	100	1.02	0.95	
STUD 75 x 30 x 1.15				
NOGGIN 72 x 32 x 1.15				

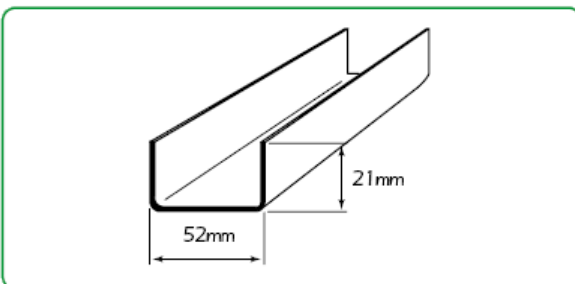

Product	Qty/Pack	APPROX KGS/LIN. MTR	THICKNESS mm	PRICE PER METRE
PLATE 54 X 20 X 1.15	100	0.89	1.15	
STUD 52 x 21 x 1.15				
NOGGIN 50 X 22 X 1.15				

# Top Plate & Trim Angle

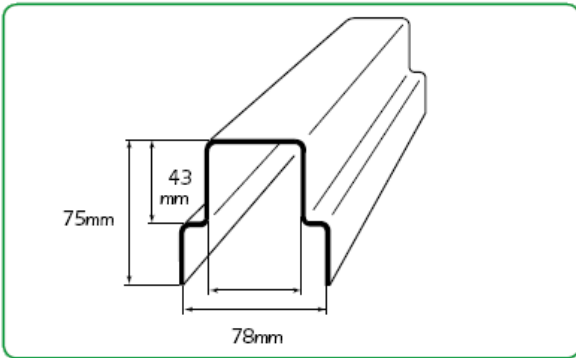

Product	Qty/Pack	APPROX KGS/LIN. MTR	THICKNESS mm	PRICE PER METRE
<b>78mm Stiffened</b>	50	1.95	1.15	
<b>Top Plate</b>	X	2.61	1.55	
G300 - AZ150	7.5m			
G300 - Z275				

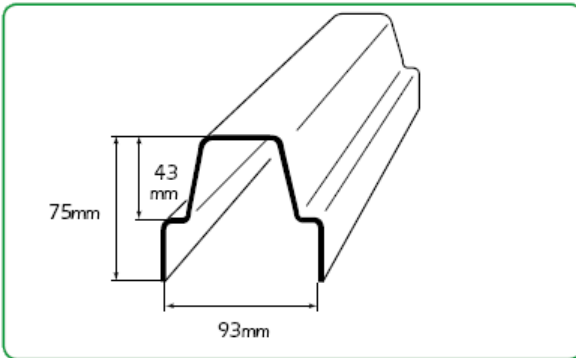

Product	Qty/Pack	APPROX KGS/LIN. MTR	THICKNESS mm	PRICE PER METRE
<b>93mm Stiffened</b>	50	2.13	1.15	
<b>Top Plate</b>	X			
G300 - AZ150	7.5m			

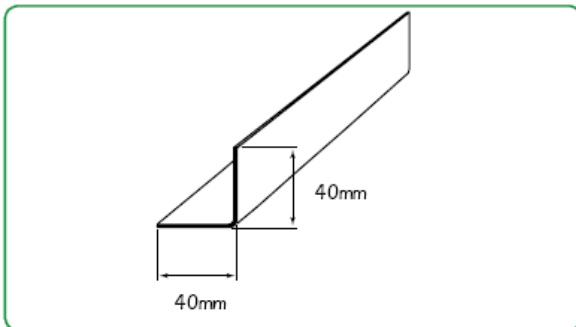

Product	Qty/Pack	APPROX KGS/LIN. MTR	THICKNESS mm	PRICE PER METRE
<b>40mm</b>	100	0.74	1.15	
<b>Trim Angle</b>	X			
G300 - AZ150	4.8m			
G300 - Z275				

## C Purlins\*

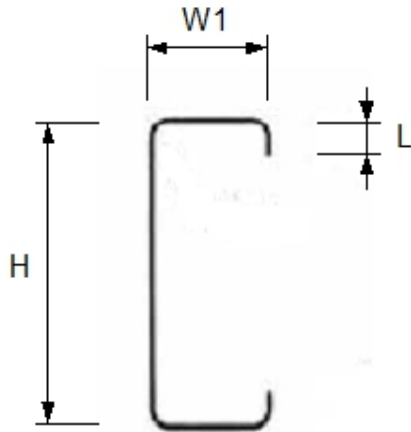

Style	Thickness		Section		Weight
	(BMT)	H	W1	L	kg/m
<b>C100</b>	<b>1.0</b>	<b>102</b>	<b>51</b>	<b>12.5</b>	<b>1.8</b>
<b>C100</b>	<b>1.15/1.2</b>	<b>102</b>	<b>51</b>	<b>13.0</b>	<b>2.1</b>
<b>C100</b>	<b>1.5</b>	<b>102</b>	<b>51</b>	<b>13.5</b>	<b>2.6</b>
<b>C100</b>	<b>1.9</b>	<b>102</b>	<b>51</b>	<b>14.0</b>	<b>3.3</b>
<b>C150</b>	<b>1.15/1.2</b>	<b>152</b>	<b>64</b>	<b>14.5</b>	<b>2.9</b>
<b>C150</b>	<b>1.5</b>	<b>152</b>	<b>64</b>	<b>15.5</b>	<b>3.6</b>
<b>C150</b>	<b>1.9</b>	<b>152</b>	<b>64</b>	<b>16.5</b>	<b>4.5</b>
<b>C150</b>	<b>2.4</b>	<b>152</b>	<b>64</b>	<b>18.0</b>	<b>5.7</b>
<b>C200</b>	<b>1.15</b>	<b>200</b>	<b>76</b>	<b>~15.0</b>	<b>3.43</b>
<b>C200</b>	<b>1.5</b>	<b>203</b>	<b>76</b>	<b>15.0</b>	<b>4.5</b>
<b>C200</b>	<b>1.9</b>	<b>203</b>	<b>76</b>	<b>18.5</b>	<b>5.7</b>
<b>C200</b>	<b>2.4</b>	<b>203</b>	<b>76</b>	<b>20.5</b>	<b>7.2</b>
<b>C250</b>	<b>1.5</b>	<b>254</b>	<b>76</b>	<b>15.5</b>	<b>5.2</b>
<b>C250</b>	<b>1.9</b>	<b>254</b>	<b>76</b>	<b>18.0</b>	<b>6.5</b>
<b>C250</b>	<b>2.4</b>	<b>254</b>	<b>76</b>	<b>21.0</b>	<b>8.2</b>
<b>C300</b>	<b>2.4</b>	<b>300</b>	<b>96</b>	<b>27.0</b>	<b>10.1</b>
<b>C300</b>	<b>3.0</b>	<b>300</b>	<b>96</b>	<b>31.0</b>	<b>12.7</b>
<b>C350</b>	<b>2.4</b>	<b>350</b>	<b>125</b>	<b>30.0</b>	<b>12.2</b>
<b>C350</b>	<b>3.0</b>	<b>350</b>	<b>125</b>	<b>30.0</b>	<b>15.2</b>
<b>C400</b>	<b>2.4</b>	<b>400</b>	<b>125</b>	<b>30.0</b>	<b>13.1</b>
<b>C400</b>	<b>3.0</b>	<b>400</b>	<b>125</b>	<b>30.0</b>	<b>16.4</b>

\* All dimensions in millimeters. Z and C purlins are available either as offcut/leftover stock (only some sizes and lengths available and dimensions may not exactly match those stated above) or new and cut to length. Lead time for new purlins can be up to 2 weeks. For new purlins, turret punching is also available (please notify requirements at time of placing order).

# Z Purlins\*

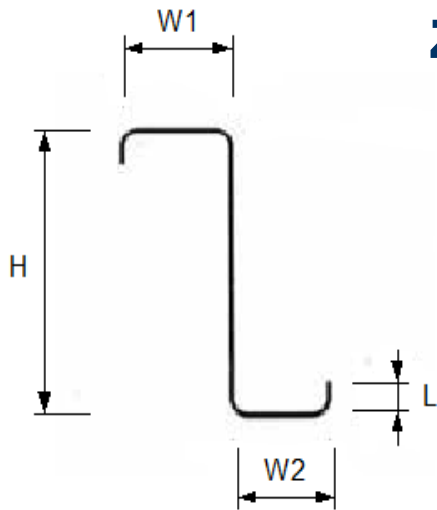

Style	Thickness		Section			Weight
	(BMT)	H	W1	W2	L	kg/m
Z100	1.0	102	53	49	12.5	1.8
Z100	1.2	102	53	49	13.0	2.1
Z100	1.5	102	53	49	13.5	2.6
Z100	1.9	102	53	48	14.5	3.3
Z150	1.2	152	65	61	14.5	2.9
Z150	1.5	152	65	61	15.5	3.6
Z150	1.9	152	65	61	16.5	4.5
Z150	2.4	152	66	60	18.0	5.7
Z200	1.5	203	79	74	15.0	4.5
Z200	1.9	203	79	74	18.5	5.7
Z200	2.4	203	79	73	20.5	7.2
Z250	1.5	254	79	74	15.5	5.2
Z250	1.9	254	79	74	18.0	6.5
Z250	2.4	254	79	73	21.0	8.2
Z300	2.4	300	100	93	27.0	10.1
Z300	3.0	300	100	93	31.0	12.7
Z350	2.4	350	129	121	30.0	12.2
Z350	3.0	350	129	121	30.0	15.2
Z400	2.4	400	129	121	30.0	13.1
Z400	3.0	400	129	121	30.0	16.4

\* All dimensions in millimeters. Z and C purlins are available either as offcut/leftover stock (only some sizes and lengths available and dimensions may not exactly match those stated above) or new and cut to length. Lead time for new purlins can be up to 2 weeks. For new purlins, turret punching is also available (please notify requirements at time of placing order).

# Channel

**Useful for joining/reinforcing purlins.**

**I.D = Internal Dimension.**

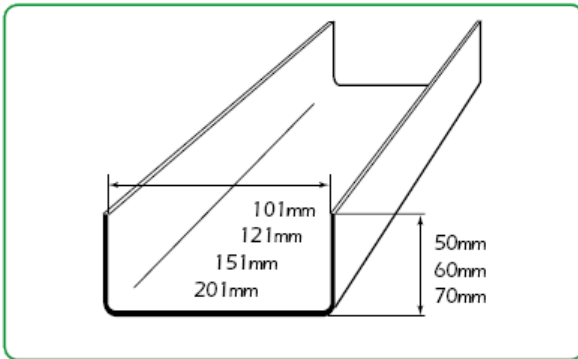

Product	Qty/Pack	APPROX KGS/LIN. MTR	THICKNESS mm	PRICE PER METRE
101 I.D Channel		1.71	1.15	
x 50		2.29	1.50	
121 I.D Channel		2.00	1.15	
x 50		2.58	1.50	
151 I.D Channel		3.16	1.50	
x 60				
201 I.D Channel		4.00	1.50	
x 70				

# Patio Tube – Galvanised or in Colorbond® Colours\*

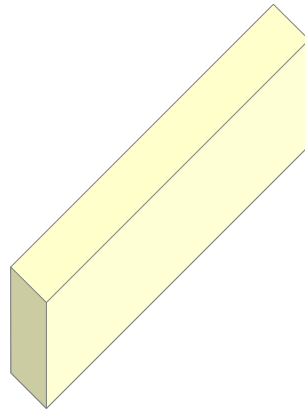

<b>Section</b>	<b>Stock Length (m)</b>	<b>Kg per Length</b>
<b>76 x 38 x 1.6mm</b>	<b>6.1</b>	<b>16.7</b>
<b>76 x 38 x 1.6mm</b>	<b>7.3</b>	<b>20.1</b>
<b>76 x 38 x 1.6mm</b>	<b>8.0</b>	<b>21.8</b>

---

\* Available in all standard Colorbond® colours, subject to a minimum order quantity. Imported stock subject to availability: all sizes and thicknesses are not always available.

# Square Hollow Section – Painted or Black\*

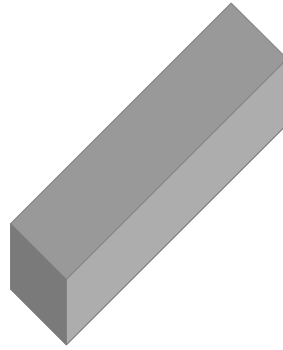

<b>Section</b>	<b>Stock Length (m)</b>	<b>Kg per Length</b>
<b>20 x 20 x 1.6mm</b>	<b>6.5</b>	<b>5.7</b>
<b>25 x 25 x 1.6mm</b>	<b>6.5</b>	<b>7.3</b>
<b>25 x 25 x 2.0mm</b>	<b>6.5</b>	<b>8.9</b>
<b>25 x 25 x 2.5mm</b>	<b>6.5</b>	<b>10.6</b>
<b>25 x 25 x 3.0mm</b>	<b>6.5</b>	<b>12.3</b>
<b>30 x 30 x 1.6mm</b>	<b>8.0</b>	<b>11</b>
<b>30 x 30 x 2.0mm</b>	<b>8.0</b>	<b>13.4</b>
<b>35 x 35 x 2.0mm</b>	<b>8.0</b>	<b>16.0</b>
<b>35 x 35 x 2.5mm</b>	<b>8.0</b>	<b>19.4</b>
<b>35 x 35 x 3.0mm</b>	<b>8.0</b>	<b>22.7</b>
<b>40 x 40 x 1.6mm</b>	<b>8.0</b>	<b>15.0</b>
<b>40 x 40 x 2.0mm</b>	<b>8.0</b>	<b>18.4</b>
<b>40 x 40 x 2.5mm</b>	<b>8.0</b>	<b>22.6</b>
<b>40 x 40 x 3.0mm</b>	<b>8.0</b>	<b>26.2</b>
<b>40 x 40 x 4.0mm</b>	<b>8.0</b>	<b>33.6</b>

\* Imported stock subject to availability: all sizes and thicknesses are not always available.



<b>Section</b>	<b>Stock Length (m)</b>	<b>Kg per Length</b>
<b>50 x 50 x 1.6mm</b>	<b>8.0</b>	<b>19.0</b>
<b>50 x 50 x 2.0mm</b>	<b>8.0</b>	<b>23.5</b>
<b>50 x 50 x 2.5mm</b>	<b>8.0</b>	<b>28.7</b>
<b>50 x 50 x 3.0mm</b>	<b>8.0</b>	<b>34.0</b>
<b>50 x 50 x 4.0mm</b>	<b>8.0</b>	<b>43.3</b>
<b>50 x 50 x 5.0mm</b>	<b>8.0</b>	<b>51.9</b>
<b>65 x 65 x 2.5mm</b>	<b>8.0</b>	<b>38.2</b>
<b>65 x 65 x 3.0mm</b>	<b>8.0</b>	<b>45.1</b>
<b>65 x 65 x 4.0mm</b>	<b>8.0</b>	<b>58.3</b>
<b>65 x 65 x 5.0mm</b>	<b>8.0</b>	<b>70.7</b>
<b>65 x 65 x 6.0mm</b>	<b>8.0</b>	<b>80.8</b>
<b>75 x 75 x 2.5mm</b>	<b>8.0</b>	<b>44.4</b>
<b>75 x 75 x 3.0mm</b>	<b>8.0</b>	<b>52.8</b>
<b>75 x 75 x 4.0mm</b>	<b>8.0</b>	<b>68.0</b>
<b>75 x 75 x 5.0mm</b>	<b>8.0</b>	<b>83.3</b>
<b>75 x 75 x 6.0mm</b>	<b>8.0</b>	<b>97.3</b>
<b>89 x 89 x 3.5mm</b>	<b>8.0</b>	<b>72.6</b>
<b>89 x 89 x 5.0mm</b>	<b>8.0</b>	<b>100.1</b>
<b>100 x 100 x 3.0mm</b>	<b>8.0</b>	<b>71.5</b>
<b>100 x 100 x 4.0mm</b>	<b>8.0</b>	<b>92.8</b>
<b>100 x 100 x 4.0mm</b>	<b>12.0</b>	<b>140.16</b>
<b>100 x 100 x 5.0mm</b>	<b>8.0</b>	<b>114.7</b>
<b>100 x 100 x 6.0mm</b>	<b>8.0</b>	<b>134.9</b>
<b>100 x 100 x 6.0mm</b>	<b>12.0</b>	<b>200.4</b>
<b>100 x 100 x 9.0mm</b>	<b>8.0</b>	<b>188.0</b>
<b>100 x 100 x 9.0mm</b>	<b>12.0</b>	<b>282.0</b>

<b>Section</b>	<b>Stock Length (m)</b>	<b>Kg per Length</b>
<b>125 x 125 x 4.0mm</b>	<b>8.0</b>	<b>118.6</b>
<b>125 x 125 x 5.0mm</b>	<b>8.0</b>	<b>146.0</b>
<b>125 x 125 x 5.0mm</b>	<b>12.0</b>	<b>219.0</b>
<b>125 x 125 x 6.0mm</b>	<b>8.0</b>	<b>172.6</b>
<b>125 x 125 x 9.0mm</b>	<b>8.0</b>	<b>244.8</b>
<b>150 x 150 x 5.0mm</b>	<b>8.0</b>	<b>177.4</b>
<b>150 x 150 x 5.0mm</b>	<b>12.0</b>	<b>266.1</b>
<b>150 x 150 x 6.0mm</b>	<b>8.0</b>	<b>210.2</b>
<b>150 x 150 x 6.0mm</b>	<b>12.0</b>	<b>315.0</b>
<b>150 x 150 x 9.0mm</b>	<b>12.0</b>	<b>452.0</b>
<b>200 x 200 x 5.0mm</b>	<b>8.0</b>	<b>240.2</b>
<b>200 x 200 x 5.0mm</b>	<b>12.0</b>	<b>358.8</b>
<b>200 x 200 x 6.0mm</b>	<b>8.0</b>	<b>285.6</b>
<b>200 x 200 x 6.0mm</b>	<b>12.0</b>	<b>428.4</b>
<b>200 x 200 x 9.0mm</b>	<b>8.0</b>	<b>414.4</b>
<b>200 x 200 x 9.0mm</b>	<b>12.0</b>	<b>612.0</b>
<b>250 x 250 x 6.0mm</b>	<b>8.0</b>	<b>361.0</b>
<b>250 x 250 x 9.0mm</b>	<b>8.0</b>	<b>526.5</b>
<b>250 x 250 x 9.0mm</b>	<b>12.0</b>	<b>789.7</b>

# Rectangular Hollow Section – Painted or Black\*

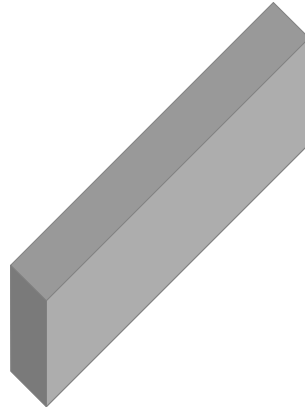

Section	Stock Length (m)	Kg per Length
50 x 25 x 1.6mm	8.0	14.0
50 x 25 x 2.0mm	8.0	17.1
50 x 25 x 2.5mm	8.0	21.0
50 x 25 x 3.0mm	8.0	24.4
65 x 35 x 2.0mm	8.0	23.4
65 x 35 x 2.5mm	8.0	28.8
65 x 35 x 3.0mm	8.0	34.0
65 x 35 x 4.0mm	8.0	43.6
75 x 50 x 2.0mm	8.0	29.7
75 x 50 x 2.5mm	8.0	36.7
75 x 50 x 3.0mm	8.0	43.2
75 x 50 x 4.0mm	8.0	55.8
75 x 50 x 5.0mm	8.0	66.8
75 x 50 x 6.0mm	8.0	79.36
100 x 50 x 2.5mm	8.0	44.5
100 x 50 x 3.0mm	8.0	52.8
100 x 50 x 4.0mm	8.0	68.4
100 x 50 x 5.0mm	8.0	83.3
100 x 50 x 6.0mm	8.0	97.3

\* Imported stock subject to availability: all sizes and thicknesses are not always available.

<b>Section</b>	<b>Stock Length (m)</b>	<b>Kg per Length</b>
<b>125 x 75 x 3.0mm</b>	<b>8.0</b>	<b>71.7</b>
<b>125 x 75 x 4.0mm</b>	<b>8.0</b>	<b>92.8</b>
<b>125 x 75 x 4.0mm</b>	<b>12.0</b>	<b>139.2</b>
<b>125 x 75 x 5.0mm</b>	<b>8.0</b>	<b>113.6</b>
<b>125 x 75 x 5.0mm</b>	<b>12.0</b>	<b>170.4</b>
<b>125 x 75 x 6.0mm</b>	<b>8.0</b>	<b>133.6</b>
<b>125 x 75 x 6.0mm</b>	<b>12.0</b>	<b>200.4</b>
<b>150 x 50 x 3.0mm</b>	<b>8.0</b>	<b>71.5</b>
<b>150 x 50 x 3.0mm</b>	<b>12.0</b>	<b>107.3</b>
<b>150 x 50 x 4.0mm</b>	<b>8.0</b>	<b>92.8</b>
<b>150 x 50 x 5.0mm</b>	<b>8.0</b>	<b>114.7</b>
<b>150 x 50 x 5.0mm</b>	<b>12.0</b>	<b>172.1</b>
<b>150 x 100 x 4.0mm</b>	<b>8.0</b>	<b>119.0</b>
<b>150 x 100 x 4.0mm</b>	<b>12.0</b>	<b>177.9</b>
<b>150 x 100 x 5.0mm</b>	<b>8.0</b>	<b>145.6</b>
<b>150 x 100 x 5.0mm</b>	<b>12.0</b>	<b>218.0</b>
<b>150 x 100 x 6.0mm</b>	<b>8.0</b>	<b>172.6</b>
<b>150 x 100 x 6.0mm</b>	<b>12.0</b>	<b>256.8</b>
<b>150 x 100 x 9.0mm</b>	<b>8.0</b>	<b>244.8</b>
<b>150 x 100 x 9.0mm</b>	<b>12.0</b>	<b>367.6</b>
<b>200 x 100 x 4.0mm</b>	<b>8.0</b>	<b>143.7</b>
<b>200 x 100 x 4.0mm</b>	<b>12.0</b>	<b>215.6</b>
<b>200 x 100 x 5.0mm</b>	<b>8.0</b>	<b>176.8</b>
<b>200 x 100 x 5.0mm</b>	<b>12.0</b>	<b>266.1</b>
<b>200 x 100 x 6.0mm</b>	<b>8.0</b>	<b>210.3</b>
<b>200 x 100 x 6.0mm</b>	<b>12.0</b>	<b>315.4</b>
<b>200 x 100 x 9.0mm</b>	<b>8.0</b>	<b>301.6</b>
<b>200 x 100 x 9.0mm</b>	<b>12.0</b>	<b>452.4</b>

<b>Section</b>	<b>Stock Length (m)</b>	<b>Kg per Length</b>
<b>250 x 150 x 5.0mm</b>	<b>8.0</b>	<b>239.2</b>
<b>250 x 150 x 5.0mm</b>	<b>12.0</b>	<b>358.8</b>
<b>250 x 150 x 6.0mm</b>	<b>8.0</b>	<b>284.8</b>
<b>250 x 150 x 6.0mm</b>	<b>12.0</b>	<b>427.2</b>
<b>250 x 150 x 9.0mm</b>	<b>12.0</b>	<b>621.6</b>

# Square Hollow Section – Galvanised\*

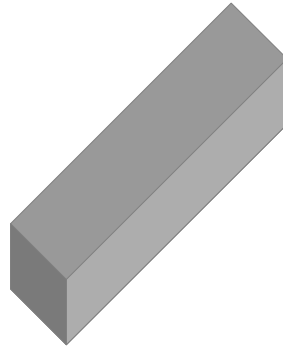

<b>Section</b>	<b>Stock Length (m)</b>	<b>Kg per Length</b>
<b>20 x 20 x 1.6mm</b>	<b>6.5</b>	<b>5.7</b>
<b>25 x 25 x 1.6mm</b>	<b>6.5</b>	<b>7.3</b>
<b>25 x 25 x 2.0mm</b>	<b>6.5</b>	<b>8.8</b>
<b>25 x 25 x 2.5mm</b>	<b>6.5</b>	<b>10.6</b>
<b>30 x 30 x 1.6mm</b>	<b>8.0</b>	<b>11.1</b>
<b>30 x 30 x 2.0mm</b>	<b>8.0</b>	<b>13.5</b>
<b>35 x 35 x 1.6mm</b>	<b>8.0</b>	<b>13.1</b>
<b>35 x 35 x 2.0mm</b>	<b>8.0</b>	<b>16.0</b>
<b>35 x 35 x 2.5mm</b>	<b>8.0</b>	<b>19.4</b>
<b>35 x 35 x 3.0mm</b>	<b>8.0</b>	<b>22.6</b>
<b>40 x 40 x 1.6mm</b>	<b>8.0</b>	<b>15.1</b>
<b>40 x 40 x 2.0mm</b>	<b>8.0</b>	<b>18.5</b>
<b>40 x 40 x 2.5mm</b>	<b>8.0</b>	<b>22.4</b>
<b>40 x 40 x 3.0mm</b>	<b>8.0</b>	<b>26.2</b>

\* Imported stock subject to availability: all sizes and thicknesses are not always available. Powdercoating available in all standard Colorbond® colours, subject to a minimum order quantity.

<b>Section</b>	<b>Stock Length (m)</b>	<b>Kg per Length</b>
<b>50 x 50 x 1.6mm</b>	<b>8.0</b>	<b>19.0</b>
<b>50 x 50 x 2.0mm</b>	<b>8.0</b>	<b>23.4</b>
<b>50 x 50 x 2.5mm</b>	<b>8.0</b>	<b>28.8</b>
<b>50 x 50 x 3.0mm</b>	<b>8.0</b>	<b>33.8</b>
<b>50 x 50 x 4.0mm</b>	<b>8.0</b>	<b>43.2</b>
<b>50 x 50 x 5.0mm</b>	<b>8.0</b>	<b>52.5</b>
<b>65 x 65 x 2.0mm</b>	<b>8.0</b>	<b>30.9</b>
<b>65 x 65 x 2.5mm</b>	<b>8.0</b>	<b>38.3</b>
<b>65 x 65 x 3.0mm</b>	<b>8.0</b>	<b>45.1</b>
<b>65 x 65 x 4.0mm</b>	<b>8.0</b>	<b>58.8</b>
<b>75 x 75 x 2.0mm</b>	<b>8.0</b>	<b>36.0</b>
<b>75 x 75 x 2.5mm</b>	<b>8.0</b>	<b>44.5</b>
<b>75 x 75 x 3.0mm</b>	<b>8.0</b>	<b>52.7</b>
<b>75 x 75 x 4.0mm</b>	<b>8.0</b>	<b>67.8</b>
<b>75 x 75 x 5.0mm</b>	<b>8.0</b>	<b>83.9</b>
<b>89 x 89 x 3.5mm</b>	<b>8.0</b>	<b>72.6</b>
<b>90 x 90 x 2.0mm</b>	<b>6.2</b>	<b>33.8</b>
<b>90 x 90 x 2.0mm</b>	<b>8.0</b>	<b>43.0</b>
<b>100 x 100 x 2.0mm</b>	<b>8.0</b>	<b>48.4</b>
<b>100 x 100 x 3.0mm</b>	<b>8.0</b>	<b>71.7</b>
<b>100 x 100 x 4.0mm</b>	<b>8.0</b>	<b>93.5</b>
<b>100 x 100 x 5.0mm</b>	<b>8.0</b>	<b>113.6</b>

# Rectangular Hollow Section – Galvanised\*

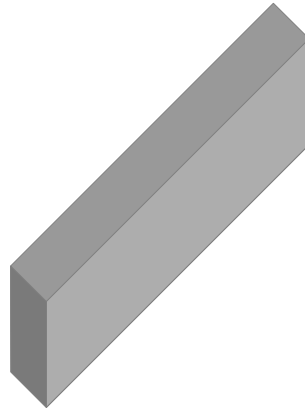

<b>Section</b>	<b>Stock Length (m)</b>	<b>Kg per Length</b>
<b>50 x 25 x 1.6mm</b>	<b>8.0</b>	<b>14.0</b>
<b>50 x 25 x 2.0mm</b>	<b>8.0</b>	<b>17.2</b>
<b>50 x 25 x 2.5mm</b>	<b>8.0</b>	<b>20.9</b>
<b>50 x 25 x 3.0mm</b>	<b>8.0</b>	<b>24.6</b>
<b>65 x 35 x 3.0mm</b>	<b>8.0</b>	<b>34.0</b>
<b>75 x 50 x 1.6mm</b>	<b>8.0</b>	<b>24.1</b>
<b>75 x 50 x 2.0mm</b>	<b>8.0</b>	<b>29.7</b>
<b>75 x 50 x 2.5mm</b>	<b>8.0</b>	<b>36.6</b>
<b>75 x 50 x 3.0mm</b>	<b>8.0</b>	<b>43.2</b>
<b>75 x 50 x 4.0mm</b>	<b>8.0</b>	<b>55.8</b>
<b>100 x 50 x 1.6mm</b>	<b>8.0</b>	<b>29.0</b>
<b>100 x 50 x 2.0mm</b>	<b>6.5</b>	<b>29.3</b>
<b>100 x 50 x 2.0mm</b>	<b>8.0</b>	<b>36.0</b>
<b>100 x 50 x 2.5mm</b>	<b>8.0</b>	<b>44.5</b>
<b>100 x 50 x 3.0mm</b>	<b>8.0</b>	<b>52.6</b>
<b>100 x 50 x 4.0mm</b>	<b>8.0</b>	<b>68.4</b>
<b>100 x 50 x 5.0mm</b>	<b>8.0</b>	<b>80.0</b>

\* Imported stock subject to availability: all sizes and thicknesses are not always available. Powdercoating available in all standard Colorbond® colours, subject to a minimum order quantity.



<b>Section</b>	<b>Stock Length (m)</b>	<b>Kg per Length</b>
<b>125 x 75 x 3.0mm</b>	<b>8.0</b>	<b>71.7</b>
<b>125 x 75 x 4.0mm</b>	<b>8.0</b>	<b>93.5</b>
<b>125 x 75 x 5.0mm</b>	<b>8.0</b>	<b>115.2</b>
<b>150 x 50 x 2.0mm</b>	<b>6.5</b>	<b>39.5</b>
<b>150 x 50 x 2.0mm</b>	<b>8.0</b>	<b>48.4</b>
<b>150 x 50 x 3.0mm</b>	<b>8.0</b>	<b>71.4</b>
<b>150 x 50 x 4.0mm</b>	<b>8.0</b>	<b>93.8</b>
<b>150 x 50 x 5.0mm</b>	<b>8.0</b>	<b>113.6</b>

# Conditions of Sale

The following conditions apply to all purchases from Best Buy Steel, whether via our website or any other means:

## 1. Acceptance of Quotes/Orders

- 1.1. If your order includes cutting or made-to-order products, you are required to verify that the products, materials, profiles, dimensions, thicknesses, measurements, finishes, colours and quantities have been quoted correctly by formally accepting your quote *and* these Terms and Conditions.
- 1.2. We always try our hardest to get orders correct but rare errors do occur and we expect you to double check your order carefully for errors before we go ahead with manufacture.
- 1.3. Once you have accepted a quote, you must also accept the goods supplied as long as they conform to that quote. For example, if you formally accept a quote listing cream coloured corrugated roof sheeting and we deliver cream coloured corrugated roof sheeting you cannot then say you will not accept the sheeting because you said 'green' on the phone but we must have heard 'cream'. We recommend that you let us send you a quote via email or fax before accepting any quote.
- 1.4. To verify that you have formally accepted your quote, as well as that you have accepted these Terms and Conditions, we require you to advise us of acceptance verbally or in writing. This can be done in several ways:
  - a) By sending us an SMS message from the mobile phone number listed on your quote. The message must include the Quote number on your quote and some phrase indicating we can proceed. Any affirmative statement will be taken as your approval of the order, for example: "Please go ahead with Quote Q1501-012345" or "Q1501-012345 is correct" or "Yes I wish to proceed with Q 012345" would all be taken as indication that you have checked the quote carefully.
  - b) By sending us an email stating the quote number and an affirmative statement indicating that we can proceed (i.e. a phrase as described for SMS messages above) or a reply to an email containing a quote from us where you make an affirmative statement indicating that we can proceed.
  - c) By sending us a fax stating the quote number and an affirmative statement indicating that we can proceed (i.e. a phrase as described for SMS messages above).
  - d) By signing the authorisation at the bottom of the quote and handing it to us in person or emailing, faxing or sending us a photo of the signed form (note that a photo must clearly show your name, signature and the date **as well as** the quote number in a single photo).
  - e) By agreeing to proceed in a recorded telephone conversation in which either party has either stated the quote number and/or stated or enumerated the products/services to be provided.

## 2. Payment

- 2.1. For trade credit account holders, payment terms are specified in the account holder's Credit Approval Letter.
- 2.2. For all other customers:
  - a) For orders of new materials, if they include cutting or made-to-order products, pre-payment is required before your order can be actioned. Payment can be made by cash or ETFPOS in person, by credit card over the phone, by bank transfer / direct deposit or by sending a cheque to our postal address. In the case of a deposit or cheque, your order will be actioned once the funds clear.
  - b) Any balance of payment for goods shall be paid C.O.D. unless otherwise arranged **prior** to delivery.
- 2.3. Payments more than 7 days overdue may incur additional charges, including but not limited (except by law) to:
  - a) costs and disbursements incurred in pursuing any recovery action
  - b) interest on overdue balances at a rate no less than the Reserve Bank of Australia's 'Indicator Lending Rates – F5 – Small Business Variable Other Overdraft (FILRSBVOO)' rate for the relevant month.
  - c) any other claim or remedy including collection costs, debt recovery fees and legal costs on an indemnity basis.
- 2.4. Such costs and disbursements will be due and payable by you to us irrespective of whether pursuit of the recovery action, claim or remedy is successful.

## 3. Delivery

- 3.1. Whilst all reasonable care will be taken when goods are being delivered, we accept no responsibility for damage to property caused during unloading of the goods, whether through negligence of our employees or agents or otherwise. Liability is only accepted for damage to the goods being delivered and is limited to a refund for the value of the goods or replacement with equivalent/comparable goods.
- 3.2. When delivering goods, we will place the goods in one of the following locations, as deemed appropriate by the person making the delivery -
  - a) On the verge of the property indicated as the delivery address for your order; or
  - b) Within the boundaries of the property indicated as the delivery address for your order, in any location on the ground that allows sufficient room for the goods to be unloaded; or
  - c) In some other location as directed by you if deemed appropriate and possible by the person making the delivery.

#### 4. Returns

- 4.1. In the interest of keeping our prices as low as possible, we cannot accept returns of made-to-order products or cut-to-order lengths for any of our products.
- 4.2. Stock lengths of new products can sometimes be returned, provided the goods are in the same condition as when they were delivered. Goods damaged in any way, including by weather, cannot be returned. If the product is an item that we already held in stock at the time of supply to you, no re-stocking fee will apply. However, if the products have been sourced especially for you from one or more of our wholesale suppliers, and we need to return the products to our wholesale suppliers, a re-stocking fee equal to that charged to us by the supplier shall be payable by you. This fee is often between 20 and 50% of the cost of the goods. If the goods were not already held in stock by us at the time of supply to you and they cannot be returned to our wholesale suppliers, you must keep and pay for the goods.
- To avoid being surprised by re-stocking fees, please ask about the re-stocking fee that applies to the products you are ordering **before placing the order**, especially if there is any risk that you will need to return stock lengths.*
- 4.3. Returned items shall be transported at your cost to whichever one of our warehouses is nearest the delivery address. We can arrange transport of any returned goods for a fee that shall be less than or equal to the initial delivery fee for the goods.

#### 5. Liability

- 5.1. Our liability for supply of the products and/or services ends with the supply of the goods and/or services as specified in the quote accepted by you as described in clause 1. Acceptance of Quotes/Orders above or, in the event of no record of acceptance, as specified in the last quote or invoice provided to you before:
- a) Manufacture in the case of made-to-order and cut-to-order items
  - b) Pick-up or despatch for delivery in the case of stock items.
- 5.2. Any notification to request changes shall be void and have no effect if sent by you or received by us after the times specified in 5.1.a) and 5.1.b).
- 5.3. Unless you have advised us by fax or email of changes required to specifications of goods, before manufacture for made-to-order and cut-to-order items and before pick-up or despatch for delivery of stock items, then the goods specified as per 5.1. shall be deemed to be the goods ordered by you.
- 5.4. Should you telephone us prior to the times specified in 5.1.a) and 5.1.b) to request changes, such changes shall only be deemed to have been made once we have issued to you a new quote/invoice incorporating such changes.

- 5.5. If, after pick-up/delivery, you believe that the wrong goods have been supplied, you must notify us within 7 days for us to accept liability for any mistake, unless a longer period is required by law.
- 5.6. If you send us copies of plans for your structure, we may calculate the quantity of materials required in order to assist you. We are not builders or engineers however and, whilst we will try our utmost to provide the best possible service we can, we cannot accept any liability for mistakes made in identifying the correct materials or in calculating the required quantities from your plans. We will provide our 'best effort' quote and then it is your responsibility to check, with a suitably qualified professional if necessary, that the materials and quantities are correct and suitable for their intended purpose.
- 5.7. Liability for goods passes from us to you when the earliest of the following occurs:
- a) When goods are being delivered, when all the goods have been placed -
    - On the ground at the delivery address for your order; or
    - At some other location as directed by you; or
    - At the location within the perimeter of the delivery address or on the verge outside the delivery address determined by the person making the delivery as most appropriate at the time of delivery
  - b) When goods are being collected, when all the goods have been -
    - Loaded onto your vehicle regardless of whether they have yet been secured; or
    - Placed beside your vehicle to allow them to be loaded onto the vehicle by you

## **6. Delay**

- 6.1. We undertake to deliver or make available each order as soon as practicable and/or by the agreed delivery date, if any such date exists. We will not however be responsible for any loss or damage arising from any delay or failure to deliver the goods, particularly if that delay or failure is caused by factors beyond our control.

## **7. Cancellation**

- 7.1. Notice of cancellation of orders must be given prior to the commencement of the cutting or manufacture of the goods. Notification after this time cannot be accepted and the conditions specified in clause 4. Returns (above) shall then apply.
- 7.2. The purchaser must compensate Best Buy Steel for any expenses related to the order that are incurred prior to receipt of notification of the cancellation or its actioning by our suppliers where applicable. Whilst we will endeavour to contact our suppliers immediately to action a cancellation, we may require up to one full business day to contact our suppliers to cancel an order and our suppliers may require 24 hours to effect the cancellation of an order.

# Alphabetical Index

## A

Angle - Trim.....	27
Apron Flashing.....	3, 18

## B

Barge Capping.....	3, 18
Battens.....	3, 17
Ceiling Battens.....	17
Roof Battens.....	17
Top Hat.....	24
Building Blanket Insulation.....	3, 23

## C

Cee Purlins.....	3, 28
Ceiling Battens.....	3, 17
Channel.....	30
Corner Mould.....	3, 19
Cover Flashing.....	3, 20
Custom Flashings.....	3, 21
Custom Orb.....	3, 5

## D

Downpipe.....	3, 12, 13
---------------	-----------

## F

Fascia.....	3, 16
Fasteners.....	3, 22
Fixings.....	3, 22
Flashings.....	
Apron Flashing.....	3, 18
Barge Capping.....	3, 18
Corner Mould.....	3, 19
Cover Flashing.....	3, 20
Custom Flashings.....	3, 21
Flat Top Ridge Capping.....	3, 15
Hookover Flashing.....	3, 20
Overflashing.....	3, 20
Rolled Top Ridge Capping.....	3, 14
Secret Gutter.....	3, 21
Flues.....	3, 23
Flume Vents.....	3, 23
Framing.....	26

## G

Guttering.....	
----------------	--

Federation Guttering.....	8
Guttering.....	3, 7, 8, 9, 10, 11
QuickFix Guttering.....	9
Secret Gutter.....	3, 21
Square Guttering.....	10
Steeline Guttering.....	7
Valley Guttering.....	11
H	
Hookover Flashing.....	3, 20
I	
Insulation.....	3, 23
J	
Junction Stud.....	25
N	
Noggin.....	26
O	
Overflashing.....	3, 20
P	
Patio Tube.....	3, 31
Plate.....	26, 27
Purlins.....	
C Purlins.....	3, 28
Channel.....	30
Z Purlins.....	3, 29
R	
Rainwater Products.....	
Downpipe.....	3, 12, 13
Patio Guttering.....	9
Secret Gutter.....	3, 21
Square Guttering.....	10
Standard Guttering.....	3, 7, 8, 9, 10, 11
Valley Guttering.....	11
Rectangular Hollow Section.....	3, 35, 40
RHS.....	3, 35, 40
Ridge Capping.....	
Flat Top Ridge Capping.....	3, 15
Rolled Top Ridge Capping.....	3, 14
Roof Battens.....	3, 17
S	
Sarking.....	23

Secret Gutter.....	3, 21
Sheeting.....	
Corrugated Sheeting.....	3, 5
Trimdek Sheeting.....	3, 6, 22
SHS.....	3, 32, 38
Square Hollow Section.....	3, 32, 38
Stud Framing.....	
Junction.....	25
Noggin.....	26
Plate.....	26, 27
Stud.....	26
T	
Tek Screws.....	22
Top Hat.....	24
Top Plate.....	27
Trim Angle.....	27
Trimdek.....	3, 6, 22
Tubing.....	
Patio Tube.....	3, 31
RHS.....	3, 35, 40
SHS.....	3, 32, 38
Z	
Zed Purlins.....	3, 29